

Sono stati rilasciati i nuovi tool che integrano il nuovo sensore PT-MAP 5.5 (fig.1).

**ATTENZIONE: PER IL TOOL CONTATTARE IL FORNITORE DEL KIT.**

**Attenzione:**

Il nuovo sensore PT-MAP 5.5 (che può avere i seguenti cod. 463000045,463000046,463000051) si differenzia dal vecchio, dal dettaglio come mostrato sotto (marcatura 5.5):

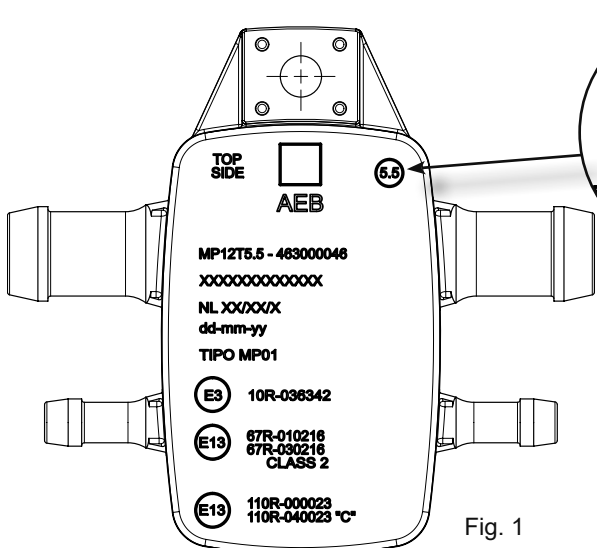

Fig. 1

**NUOVO PT-MAP**

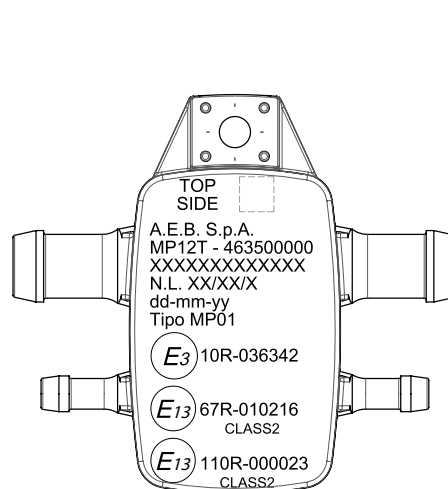

Fig. 2

**VECCHIO PT-MAP**

Selezionare il nuovo tipo di sensore AEB5P5 dal menu a tendina (versione software Multipoint):

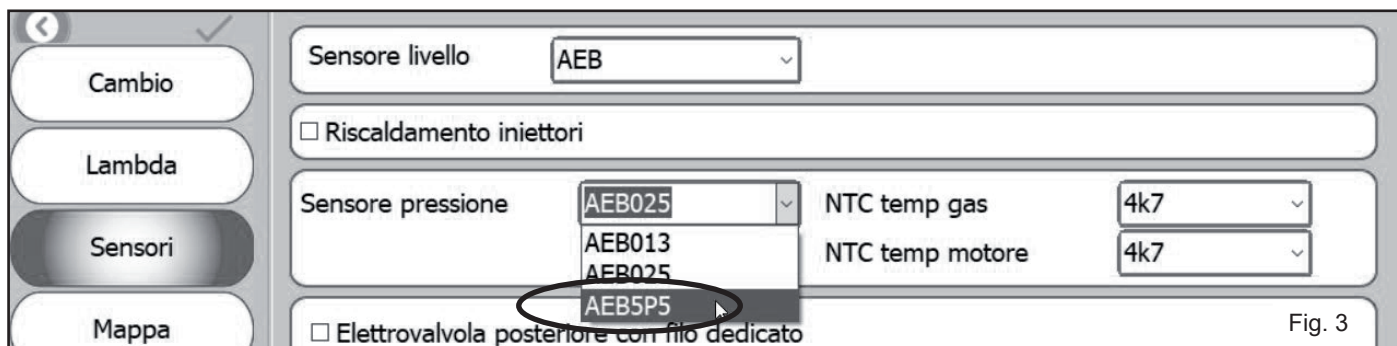

Fig. 3

Selezionare il nuovo tipo di sensore AEB5P5 dal menu a tendina (versione software Direct Injection):

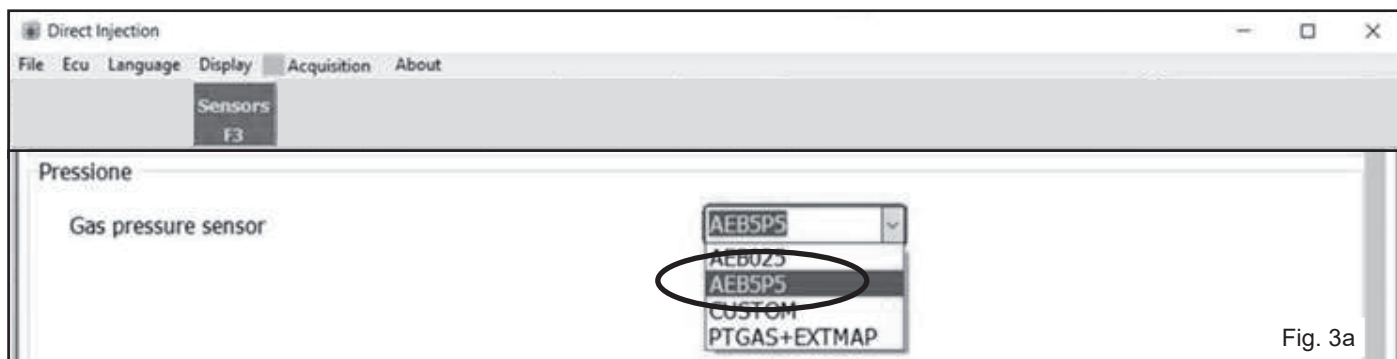

Fig. 3a

190000112 - Rev.00 - 11/04/2022

**ATTENZIONE: selezionando il sensore AEB5P5, il file di mappa non subirà cambiamenti.**

The new tools has been released that integrates the new PT-MAP 5.5 sensor (fig. 1).



**ATTENTION: FOR THE TOOL PLEASE CONTACT THE SUPPLIER OF THE KIT.**

**Attention:**

The new PT-MAP 5.5 sensor (that can have the following codes 463000045,463000046,463000051) differs from the old one, by the detail shown below (marking 5.5):

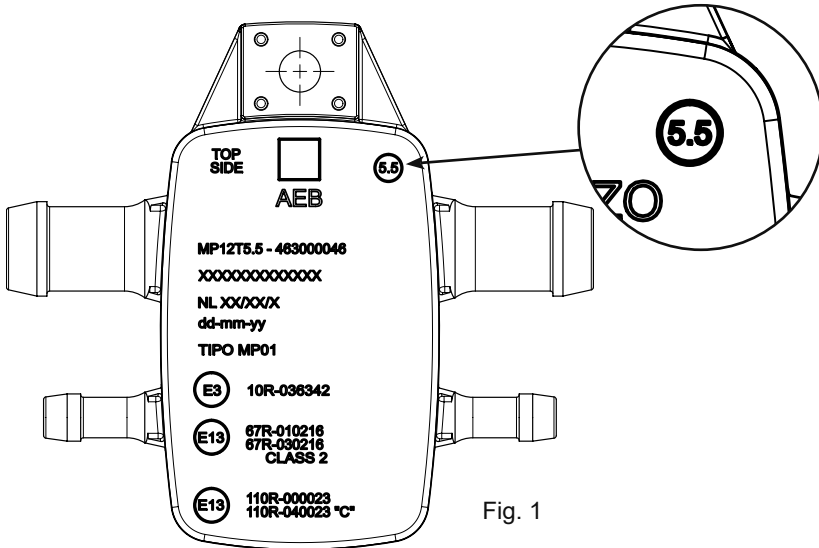

Fig. 1

**NEW PT-MAP**

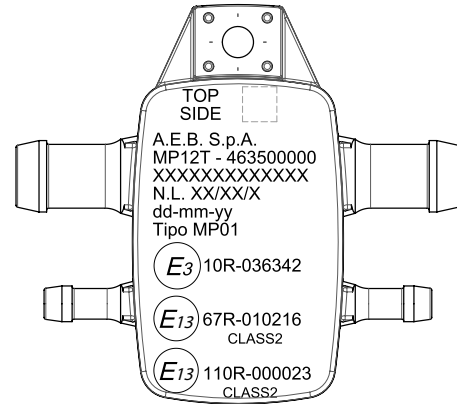

Fig. 2

**OLD PT-MAP**

Select the new sensor type AEB5P5 from the selective window menu (Multipoint software version):

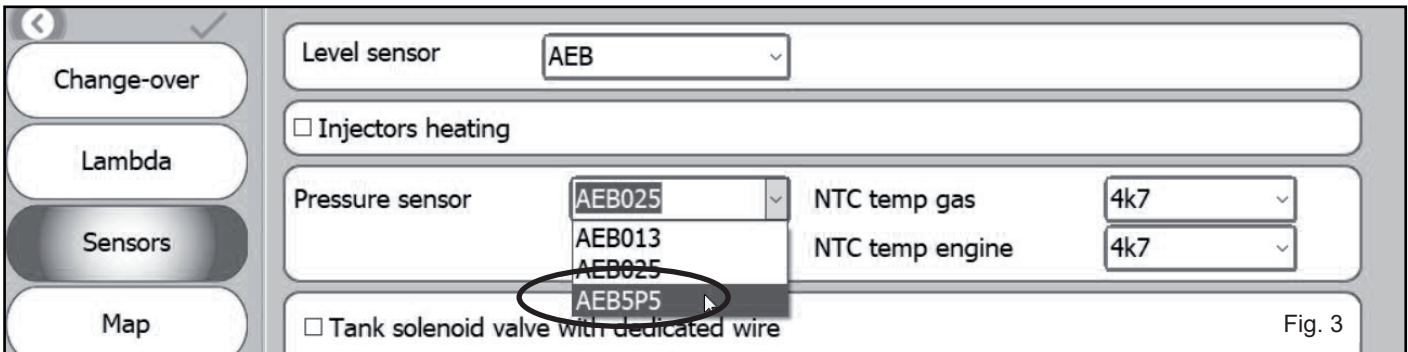

Fig. 3

Select the new sensor type AEB5P5 from the selective window menu (Direct Injection software version):

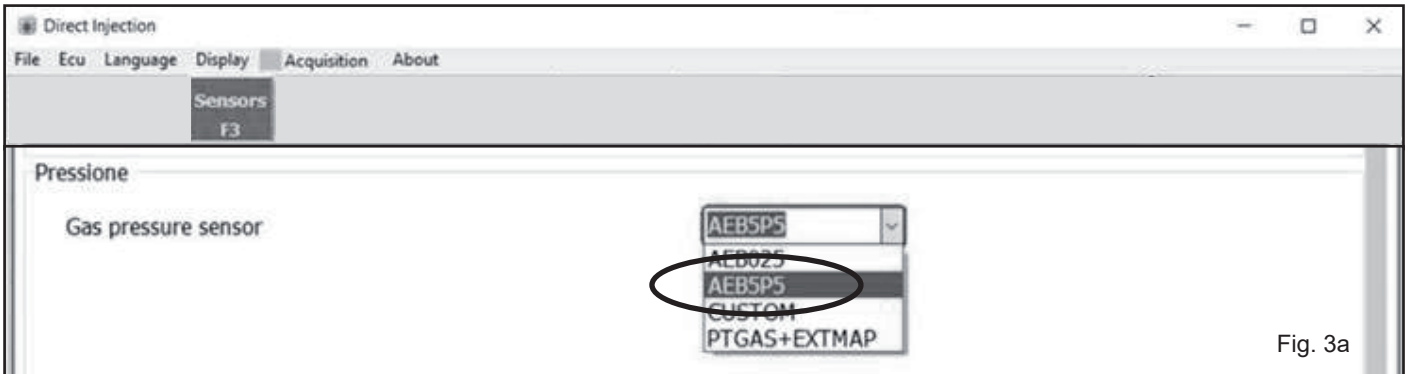

Fig. 3a

190000112 - Rev.00 - 11/04/2022

**ATTENTION: by selecting the AEB5P5 sensor, the map file will not be changed.**

Se ha lanzado el nuevo Software que integra el nuevo sensor PT-MAP 5.5 (fig. 1).



**ATENCIÓN: PARA SOLICITAR EL SOFTWARE CONTACTAR AL PROVEEDOR DEL KIT.**

**Atención:**

El nuevo sensor PT-MAP 5.5 (que puede tener lo siguiente códigos 463000045,463000046,463000051) se diferencia del anterior por el detalle que se muestra a continuación (marca 5.5):

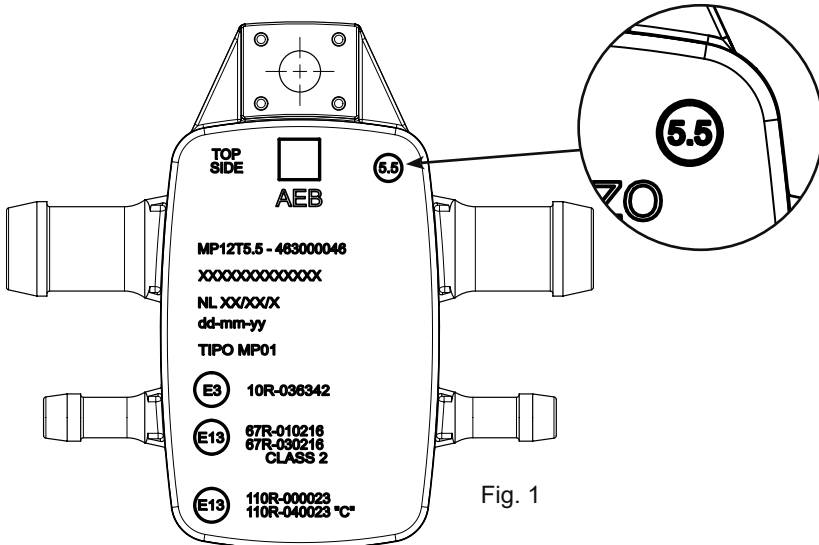

Fig. 1

**NUEVO PT-MAP**

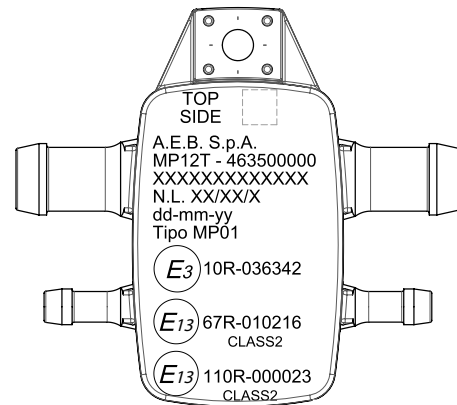

Fig. 2

**VIEJO PT-MAP**

Seleccione el nuevo tipo de sensor AEB5P5 en el menú de la ventana selectiva (versión de software multipunto):

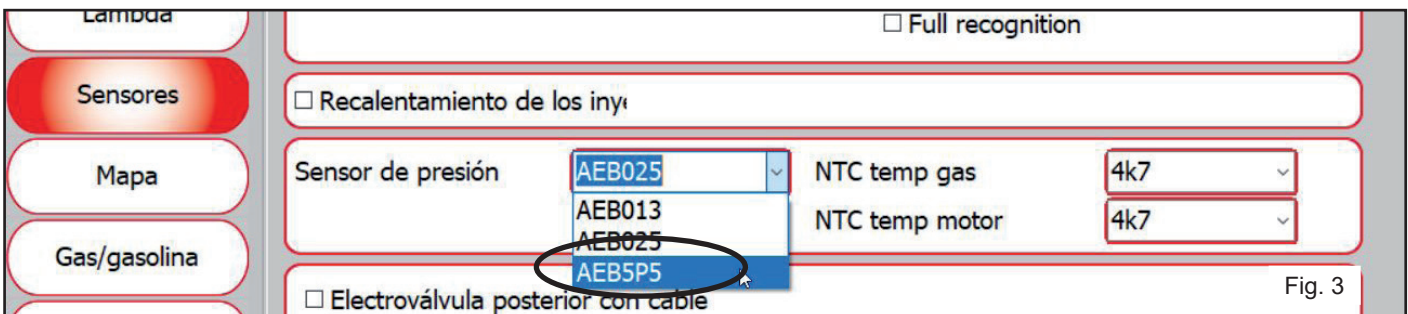

Fig. 3

Seleccione el nuevo tipo de sensor AEB5P5 en el menú de la ventana selectiva (versión del software de inyección directa):

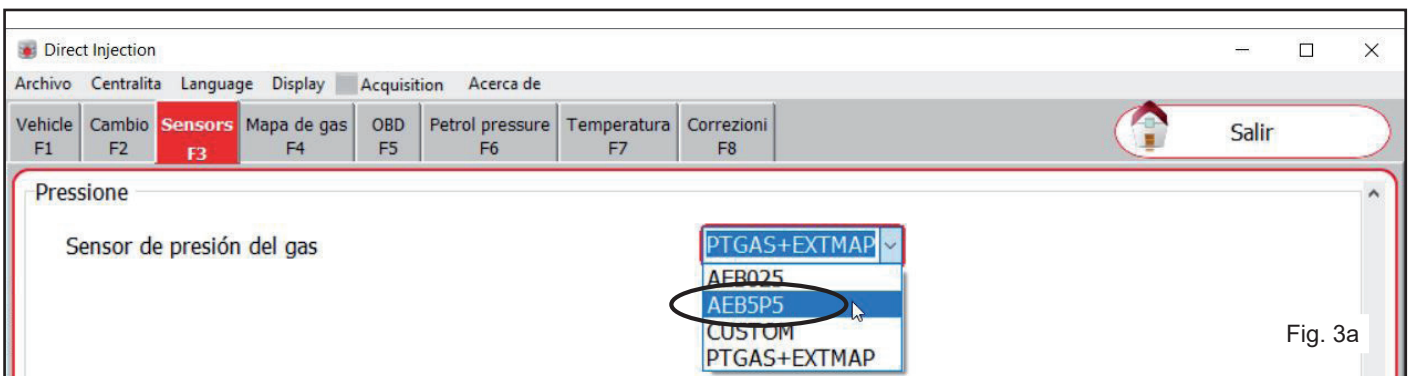

Fig. 3a

**ATENCIÓN: al seleccionar el sensor AEB5P5, el archivo del mapa no se modificará.**

Foi lançado o novo Software que integra o novo sensor PT-MAP 5.5 (fig. 1).

**ATENCIÓN: PARA SOLICITAR EL SOFTWARE CONTACTAR AL PROVEEDOR DEL KIT.**

**Atenção:**

O novo sensor PT-MAP 5.5 (que pode ter os seguintes códigos 463000045,463000046,463000051) difere do anterior devido ao detalhe mostrado abaixo (marca 5.5):

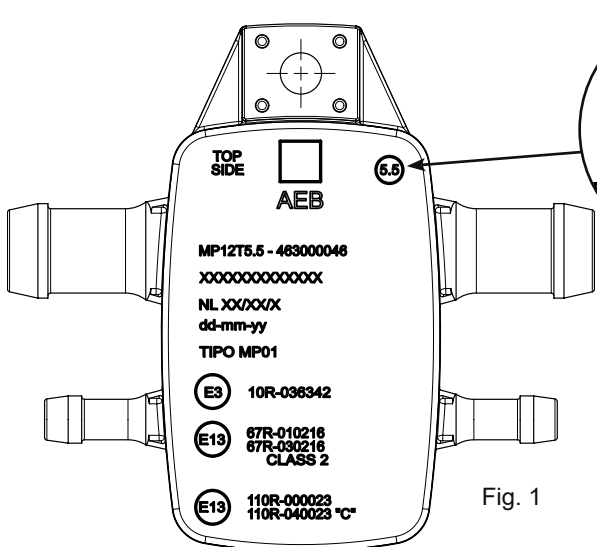

Fig. 1

**NOVO PT-MAP**

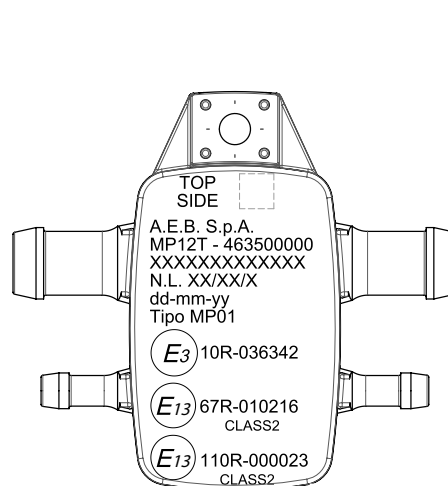

Fig. 2

**ANTIGO PT-MAP**

Selecione o novo tipo de sensor AEB5P5 no menu da janela seletiva (versão de software multiponto):

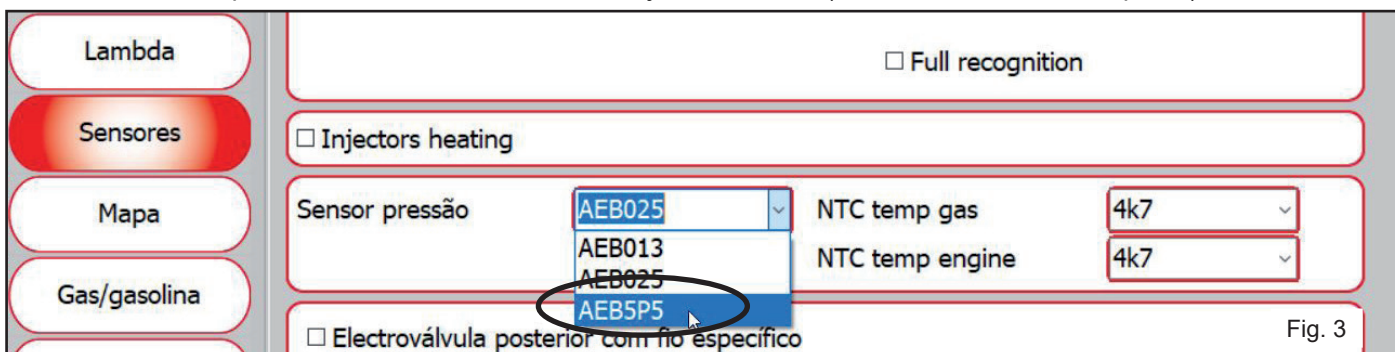

Fig. 3

Selecione o novo tipo de sensor AEB5P5 no menu da janela seletiva (versão do software de injeção direta):

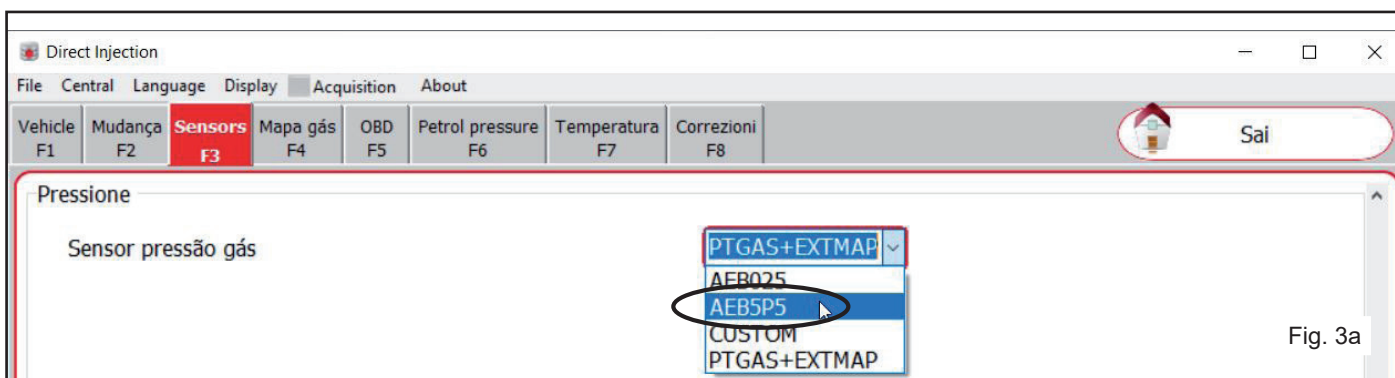

Fig. 3a

**ATENÇÃO:** ao selecionar o sensor AEB5P5, o arquivo do mapa não será modificado.

Le nouveau Software qui intègre le nouveau capteur a été lancé PT-MAP 5.5 (fig. 1).



**ATTENTION!! : POUR DEMANDER LE SOFTWARE, CONTACTER LE FOURNISSEUR DU KIT.**

**Attention!!**

Le nouveau capteur 5.5 PT-MAP (qui peut avoir les codes suivants 463000045,463000046,463000051) diffère du précédent par le détail indiqué en haut à droite (l'écriture 5.5 Fig.1-2):

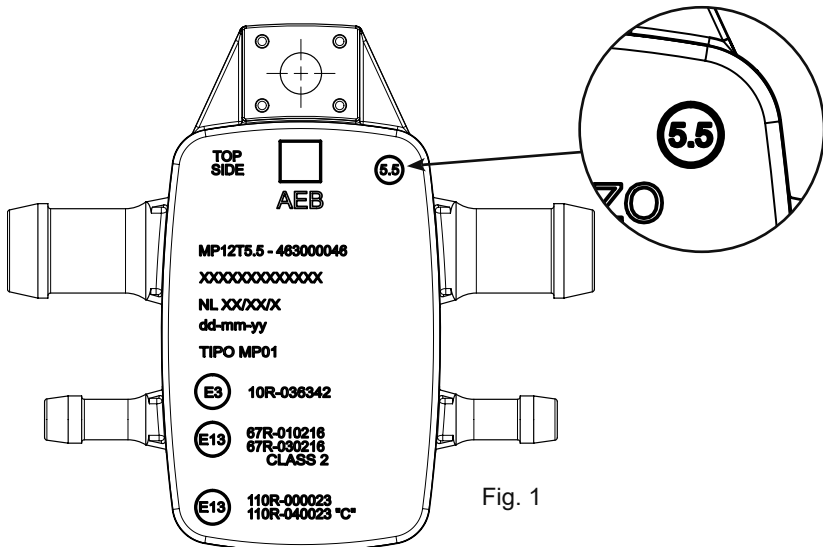

Fig. 1

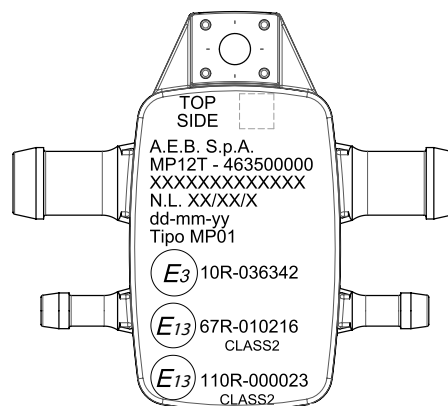

Fig. 2

**NOUVEAU PT-MAP**

**ANCIEN PT-MAP**

Sélectionner le nouveau type de capteur AEB5P5 dans le menu de la fenêtre "Capteur de pression" (version Software multipoint Fig.3) :

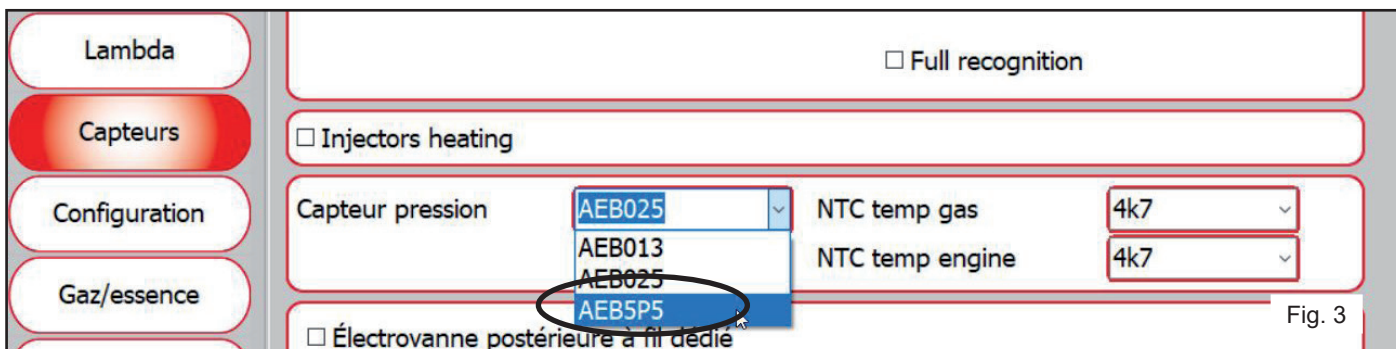

Fig. 3

Sélectionner le nouveau type de capteur AEB5P5 dans le menu de la fenêtre "Capteur de pression" (version software injection directe Fig. 3a)

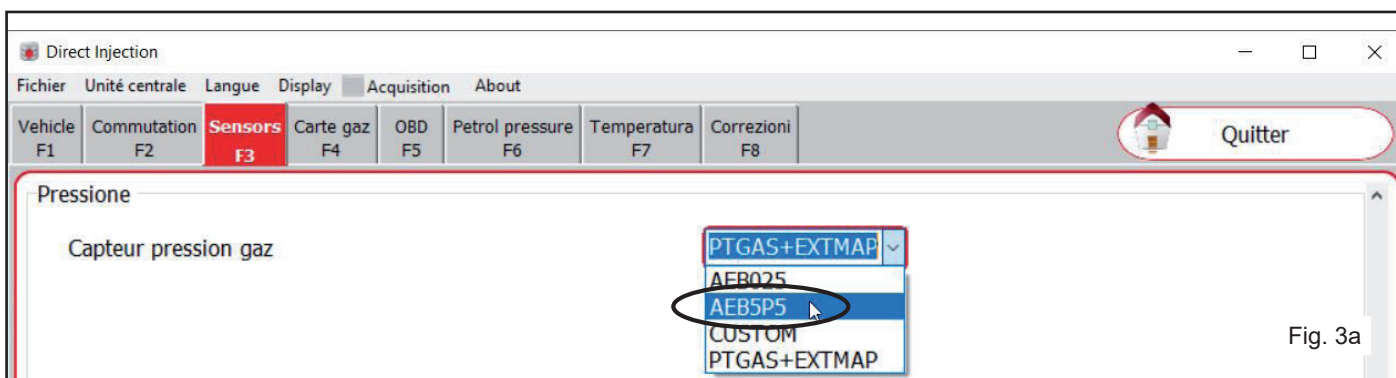

Fig. 3a

**ATTENTION!! : en sélectionnant le capteur AEB5P5, le file cartographique gaz ne sera pas modifié.**

Выпущено новое программное обеспечение, интегрирующее новый датчик PT-MAP 5.5. (fig. 1)



**ВНИМАНИЕ: ДЛЯ ЗАПРОСА ПРОГРАММНОГО ОБЕСПЕЧЕНИЯ ОБРАЩАЙТЕСЬ К ПОСТАВЩИКУ КОМПЛЕКТА.**

Внимание::

Новый датчик 5.5 PT-MAP (который может иметь следующие коды 463000045,463000046,463000051) отличается от предыдущего показанной ниже деталью (знак 5.5):

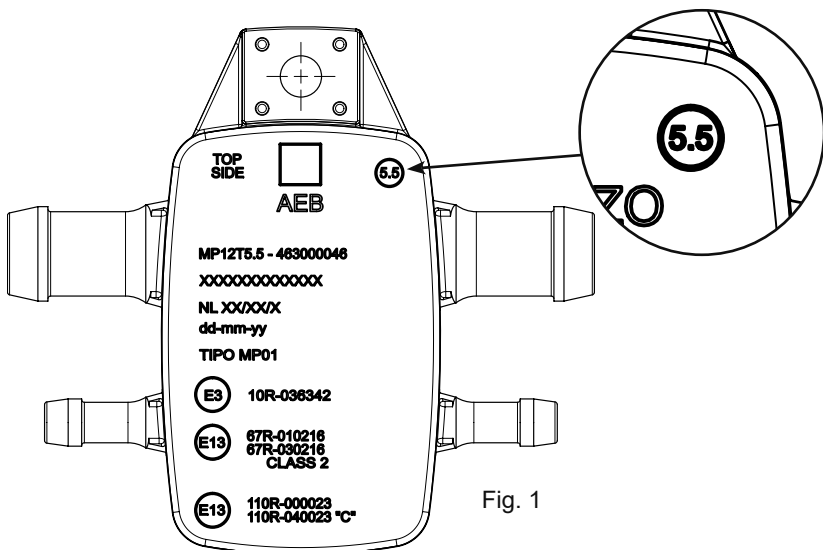

Fig. 1

**НОВЫЙ PT-MAP**

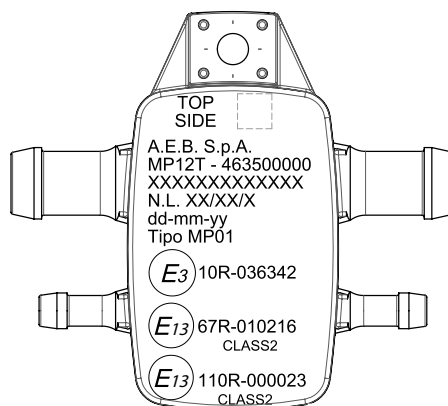

Fig. 2

**СТАРЫЙ PT-MAP**

Выберите новый тип датчика AEB5P5 в меню выборочного окна (версия многоточечного программного обеспечения):

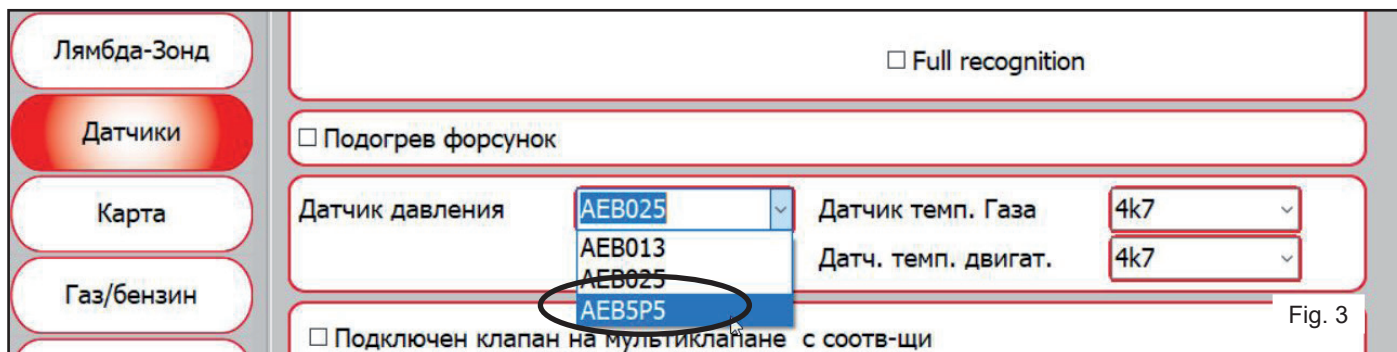

Fig. 3

Выберите новый тип датчика AEB5P5 в меню селективного окна (версия ПО прямого впрыска):

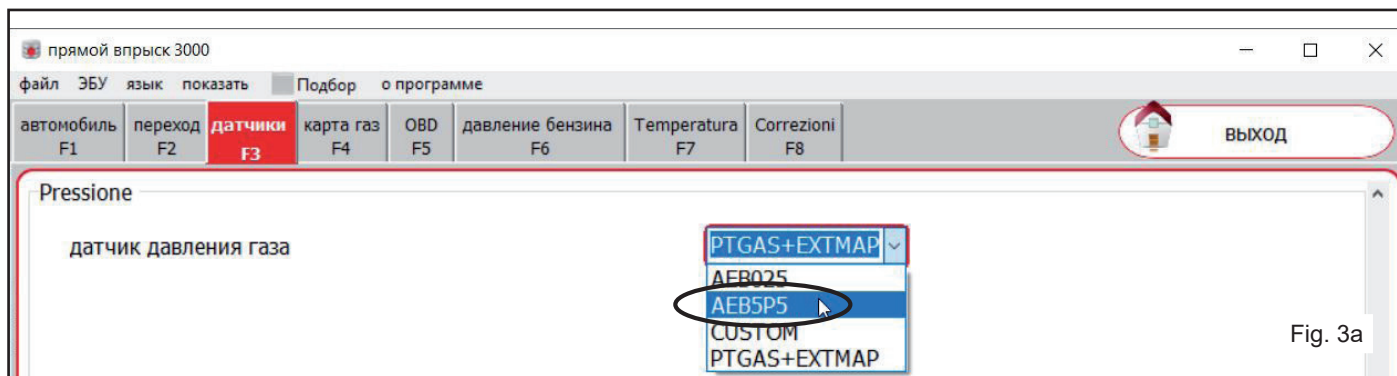

Fig. 3a

**ВНИМАНИЕ: при выборе датчика AEB5P5 файл карты не будет изменен.**

190000112 - Rev.00 - 11/04/2022